



---

# **ANFIS BASED OPPURTUNISTIC POWER CONTROL FOR COGNITIVE RADIO IN SPECTRUM SHARING**

Joyraj Chakraborty  
Venkata Krishna chaithanya varma. Jampana

This thesis is presented as part of Degree of  
Master of Science in Electrical Engineering

Blekinge Institute of Technology  
October 2012

---

**Blekinge Institute of Technology**  
**School of Engineering**  
**Department of Applied Signal Processing**  
**Supervisor: Dr. Maria Erman**  
**Examiner: Dr. Sven Johansson**



## **ABSTRACT**

Cognitive radio is a intelligent technology that helps in resolving the issue of spectrum scarcity. In a spectrum sharing network, where secondary user can communicate simultaneously along with the primary user in the same frequency band, one of the challenges in cognitive radio is to obtain balance between two conflicting goals that are to minimize the interference to the primary users and to improve the performance of the secondary user.

In our thesis we have considered a primary link and a secondary link (cognitive link) in a fading channel. To improve the performance of the secondary user by maintaining the Quality of Service (Qos) to the primary user, we considered varying the transmit power of the cognitive user. Efficient utilization of power in any system helps in improving the performance of that system. For this we proposed ANFIS based opportunistic power control strategy with primary user's SNR and primary user's channel gain interference as inputs. By using fuzzy inference system, Qos of primary user is adhered and there is no need of complex feedback channel from primary receiver. The simulation results of the proposed strategy shows better performance than the one without power control. Initially we have considered propagation environment without path loss and then extended our concept to the propagation environment with path loss where we have considered relative distance between the links as one of the input parameters.



## **ACKNOWLEDGEMENTS**

We first like to thank and appreciate our supervisor Dr. Maria Erman and Dr. Sven Johansson for their extended support and suggestions throughout the thesis work. We will be grateful to our supervisor Dr. Maria Erman for giving us the opportunity to do our Master's thesis in the fields of Cognitive radio and Neural networks. We also like to thank all our friends, whose suggestions and support helped us in completing this thesis work. We would like to thank Blekinge institute of technology (BTH) for giving us this opportunity to study our Master's in Sweden.

Finally the support and encouragement from our parents without which we couldn't have been survived in Sweden, should be mentioned. Thank you soo much to One and All.



# TABLE OF CONTENTS

<b>Abstract</b>	.....	<b>iii</b>
<b>Acknowledgement</b>	.....	<b>v</b>
<b>Table of contents</b>	.....	<b>vii</b>
<b>List of Figures</b>	.....	<b>ix</b>
<b>Short List of Abbrivations</b>	.....	<b>xi</b>
<b>1 Introduction</b>	.....	<b>1</b>
1.1 Introduction	.....	1
1.2 Thesis organisation	.....	2
<b>2 Back Ground &amp; Motivation</b>	.....	<b>3</b>
2.1 Overview of cognitive cycle	.....	3
2.2 Optimal power control and related work	.....	4
2.3 ANFIS and related work	.....	6
<b>3 Problem statment, Hypothesis and Contributions</b>	.....	<b>7</b>
3.1 Aim/Objectives	.....	7
3.2 Research questions	.....	7
3.3 Main Contributions	.....	7
<b>4 FIS and ANFIS</b>	.....	<b>8</b>
4.1 Rule based Fuzzy model	.....	8
4.2 Important definitions	.....	9
4.3 Types of Fuzzy Inference Systems (FIS)	.....	10
4.3.1 Mamdani Model	.....	10
4.3.2 Takagi-Sugeno Model	.....	11
4.3.3 Tsukamoto Model	.....	11
4.4 Adaptive Neuro Fuzzy Inference system (ANFIS)	.....	12
<b>5 System Model</b>	.....	<b>17</b>
5.1 Propagation environment without path loss	.....	17
5.2 Propagation environment with path loss	.....	20
<b>6 Implementation and Results</b>	.....	<b>23</b>
<b>7 Conclusion and Future work</b>	.....	<b>29</b>
<b>8 References</b>	.....	<b>30</b>



## LIST OF FIGURES

- Figure 1: Basic structure of Cognitive radio cycle.
- Figure 2: Rule based Fuzzy model.
- Figure 3: General Architecture of ANFIS.
- Figure 4: Flow chart of ANFIS implementation
- Figure 5: Propagation environment without path loss.
- Figure 6: Propagation environment with path loss.
- Figure 7: Structure of ANFIS.
- Figure 8: Membership function of  $\frac{\alpha}{\beta_t}$ .
- Figure 9: Membership function of  $\frac{G_{cp}}{G_{cp \max}}$ .
- Figure 10: Error minimization graph.
- Figure 11: Surface graph
- Figure 12: Performance of the secondary user.
- Figure 13: Membership function of  $\frac{\alpha}{\beta_t}$  for second scenario.
- Figure 14: Membership function of  $\frac{d_{cp}}{L_{cp}}$  for second scenario.
- Figure 15: Error minimization graph for scenario 2.
- Figure 16: Surface graph for propagation environment with path loss.



## **SHORT LIST OF ABBREVIATIONS**

PU	Primary User
SU	Secondary User
FIS	Fuzzy Inference system
ANFIS	Adaptive Neuro Fuzzy Inference System
SNR	Signal to Noise Ratio
SINR	Signal to Interference Noise Ratio
FL	Fuzzy Logic
ANN	Artificial Neural Networks
QoS	Quality of Service

# 1. INTRODUCTION

## 1.1 Introduction:

Cognitive radio is a technology which helps in the efficient utilization of the spectrum. Spectrum is a limited resource, hence the use of spectrum is regulated by government agencies like the Post and Telecom service (PTS) in Sweden, Federal Communications Commission (FCC) in United states, Telecom Regulatory Authority of India (TRAI) in India. It has been found that most of the time the spectrum is underutilized even in highly populated urban areas. There are two types of users who use the spectrum. They are the Primary users (licensed) and the secondary users (Unlicensed). The Primary users (licensed) are those that have a license to use the spectrum. The Secondary users (Unlicensed) are those who don't have a license to use the spectrum. When the assigned spectrum is not completely or if only partially utilized by the primary user, the unutilized spectrum is referred to as a spectrum hole or a white space. Cognitive radio identifies these spectrum holes and assigns them to the secondary users without causing any interference to the primary users. The concept of Cognitive radio was first introduced by Joseph Mitola III and Gerald Q. Maguire Jr. from Royal Institute of Technology, Sweden in 1999 [1],[2].

Cognitive radio comprises of spectrum sensing, spectrum management and spectrum mobility. The process of sensing the spectrum, identifying the primary users and spectrum holes without causing interference to primary users is called spectrum sensing. The process of selecting spectrum bands which is appropriate to perform communication by the cognitive user is called spectrum management. It depends on the cognitive user's requirement and the quality of service to the primary users. The process of exchanging the operating frequencies by the cognitive users for better communication is called spectrum mobility.

For Cognitive radio users, optimal power control in spectrum sharing is one of the most important research issues. Opportunistic spectrum access and spectrum sharing are two types of mechanisms in cognitive radio networks. In opportunistic spectrum access either the primary user (PU) or the secondary user (SU) can use the spectrum. When the PU is idle, the SU will be able to use the spectrum. When the PU needs to use the spectrum again, SU has to vacate the spectrum. In Spectrum sharing both PU and SU can access the spectrum simultaneously as long as there is no interference to PU's Quality of service (QoS). The operation of the SU depends on the peak transmit power constraint and an average interference constraint at the primary receiver [3]. It is important to balance the interference to the PU and improve the performance of the SU. Power control is one of the constraints to improve the performance of the secondary users.

Adaptive neuro fuzzy inference system(ANFIS) is a type of fuzzy inference system (FIS) which formulates the mapping of inputs to output. It uses both fuzzy logic(FL) and artificial neural networks(ANN) in the process of mapping the inputs to output. In FIS the most difficult part is to obtain membership functions, distribution of membership functions and setting fuzzy rules. These parameters are obtained by using trial and error method. ANFIS uses neural networks to adjust these parameters. The ANN part in ANFIS helps in reducing the error and optimizing the parameters. FL deals with uncertainty very well and known for structured knowledge representation. ANN has the learning capability. ANFIS inherited both of these advantages from the respective parts. Hence ANFIS has become an important step of research in the fields of automatic control, data classification, decision analysis, expert systems and computer vision where FIS has been successfully used. The concept of ANFIS was first proposed by J. S. R Jang in 1993 [4] .

In this thesis work we have focused on using ANFIS for optimizing the power control in Cognitive radio without disturbing the Quality of Service (Qos) to the primary users. We considered a fading channel with a pair of primary users and a pair of cognitive users. For ANFIS, we considered the ratio of Signal to noise ratio (SNR) of the primary user to a threshold value as one input. The ratio of primary user's channel gain to its maximum value was used as the second input. The Output parameter that we considered was the ratio of cognitive user's power to its maximum value. We extended the concept to the propagation environment with path loss in which we have considered relative distance between the primary link and secondary link as one of the parameter that affects the output parameter.

## **1.2 Thesis Organization:**

The thesis is organized in the following manner:

In chapter 2 we explain the background and motivation for the thesis work. We have also explained the overview of cognitive cycle.

In chapter 3 we discussed about the objectives of the thesis and Contributions from the thesis.

In chapter 4 we introduced Fuzzy inference system and different types. We also introduced Adaptive neuro fuzzy inference system and to its working process.

In chapter 5 we have introduced the system models that we used in this thesis work. We introduced spectrum sharing networks in two different propagation environments. First without path loss and the with path loss.

In chapter 6 we have discussed about the implementation and results.

In chapter 7 we have concluded and discussed about the future work.

## 2. BACKGROUND AND MOTIVATION

### 2.1 Overview of Cognitive cycle:

“Necessity is the mother of invention.” Scarcity of Spectrum has led to the invention of new technology called Cognitive radio, which can be used for effective utilization of spectrum. Cognitive radio is a technology used by the unlicensed users to use underutilized spectrum without causing any interference to the licensed users.

According to Simon Haykin [5] , the definition of Cognitive radio is *“Cognitive radio is an intelligent wireless communication system that is aware of its surrounding environment (i.e., outside world), and uses the methodology of understanding-by-building to learn from the environment and adapt its internal states to statistical variations in the incoming RF stimuli by making corresponding changes in certain operating parameters (e.g., transmit-power, carrier-frequency and modulation strategy) in real-time, with two primary objectives in mind:*

- *Highly reliable communications whenever and wherever needed;*
- *Efficient utilizations of the radio spectrum.”*

Most important features of cognitive radio is awareness, intelligence, learning, adaptability, reliability, reconfigurability. Different technologies like Software defined radio, digital signal processing, networking, machine learning and computer software & hardware helped to bring these features together in the form of Cognitive radio.

There are three fundamental tasks in the operation of Cognitive radio as shown in Figure 1 . They are

1. Radio scene analysis.
2. Channel state estimation and predictive modeling.
3. Transmit power control and spectrum management.

The first and second tasks are performed at receiver’s end however the third task is performed at the transmitter end.

Radio scene analysis: In this task there are two important actions. One is to estimate the interference temperature. Second is to identify spectrum holes. These actions are performed at the receiving end and the information is transmitted back to the transmitter through a feedback channel. This information is necessary for the transmitter in order to perform the third task.

Channel state estimation and predictive modeling: This task comprises of estimating the channel state information and to calculate the channel capacity of the cognitive link which is used by the transmitter.

Transmit power control and spectrum management: This task is performed at the transmitter end. It comprises of selecting the best transmit power levels of the unlicensed users which maximizes the data transmission rates without exceeding interference temperature. Spectrum management is necessary for effective utilization of the spectrum.

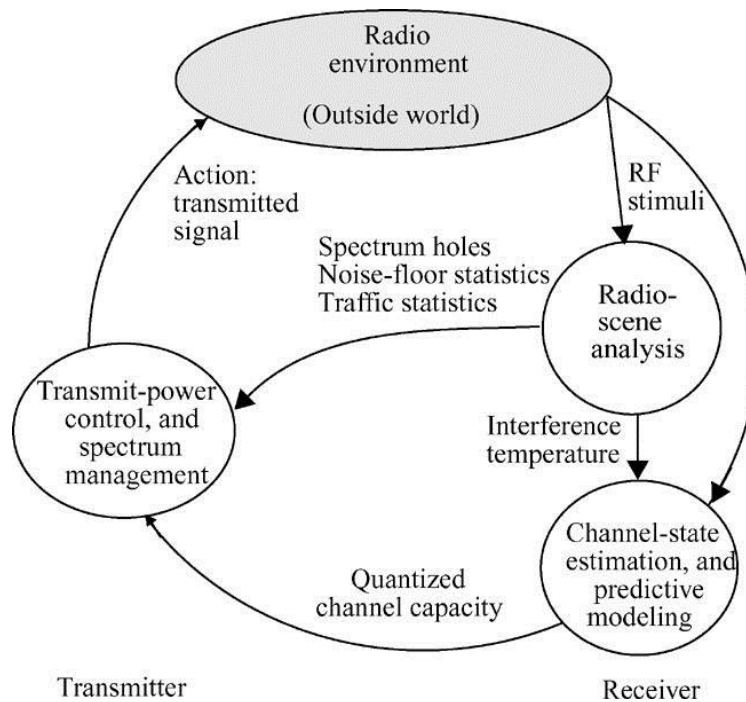

**Figure 1: Basic structure of Cognitive radio cycle**

## **2.2 Optimal power control and related work:**

In any system power control plays an important role in the performance of that system. Likewise in Cognitive radio, power control has a major role in its performance. There is always a scope of improvement when it comes to power control. Hence power control in cognitive radio has been an important research topic for researchers across the world.

In [3] the authors have considered the peak power constraint at the secondary transmitter to characterize the power adaption strategies that maximize the SNR and capacity of the secondary users. The SNR optimal power adaptation policy makes sure that transmissions take

place only at the peak power regardless of the knowledge of the secondary channel and type of sensing metric.

In [6] to maximize the ergodic capacity of secondary users, optimal power control strategies under four different power constraints have been derived via convex optimization. In this paper the authors have considered the interference power constraint and the transmission power constraint which affect the capacity of the secondary users.

In [6] [8] , the authors have considered a spectrum sharing network with a pair of primary users and secondary users in a fading channel. The primary user has the higher priority to use the spectrum than cognitive user. Cognitive user can share the spectrum as long as the desired Quality of service is maintained for the primary user. Using three input parameters: The PU's SNR, the PU's interference channel gain and the relative distance between PU's link and CR's link, a fuzzy based opportunistic power control strategy using mamdani fuzzy control has been proposed.

In [9] , the authors also considered a primary link and a secondary link in a fading channel and proposed a power control strategy in which the cognitive user can adapt transmit power opportunistically to achieve maximum transmission rate without effecting the outage probability of the primary user. With the simulation they proved that the proposed strategy achieves maximum transmission rate for cognitive link without causing interference to the primary user.

In [10] , the authors considered single transmitter which communicates with primary receivers and located at the center of the network. The network consists of multiple cognitive radio users. The authors introduced the concepts of primary exclusive region and protected radius. Authors analyzed the interference caused by cognitive transmitters to primary receivers, power scaling in cognitive users according to the distance from the primary transmitter.

In [11] , the authors considered a pair of primary users and a pair of cognitive users in a fading channel. The authors used scenarios without path loss and with path loss where distance plays an important role. An upper bound on the capacity of the cognitive user was derived using interference temperature concept. The authors interest is to maximize the Quality of service to the cognitive user without effecting the primary users transmission or causing any interference to the primary user.

### **2.3 ANFIS and related work:**

ANFIS is a combination of Neural networks and Fuzzy logic. It inherits the advantages of structured knowledge representation from Fuzzy logic and Learning capability from Neural networks. Usually in other FIS systems, expert knowledge is used to obtain the membership functions, distribution of membership functions and to set the fuzzy rules. The advantage of ANFIS is that it obtain the membership functions and set the rules by itself adaptively using the training data. ANFIS do so using different types of algorithms of neural networks like back propagation algorithm, least mean squares algorithm etc.

In the paper [12] , authors used ANFIS for copper grade prediction in Sarcheshmeh porphyry copper system. The authors also compared the proposed system with ANN based and FL based(mamdani) system and concluded that ANFIS got better results.

In [13] , author considered fixed broadband wireless access system. The author proposed and analyzed fuzzy and ANFIS based downlink power control schemes. These schemes are used to evaluate the channel quality using environmental variables like rain rate, number of users as input parameters. Channel quality is used to adjust the power control region.

In the paper [14] , author used ANFIS in cognitive radio for predicting data rate of a particular Radio configuration. With the simulation results they proved that ANFIS is more accurate and less complex in data prediction when compared to neural networks.

### **3. OBJECTIVES AND CONTRIBUTIONS**

#### **3.1 AIM/OBJECTIVES:**

The main aim of our thesis is to understand the performance of Adaptive neuro fuzzy inference system (ANFIS) in opportunistic power control of Cognitive radio and its behavior in different propagation environments. The Objectives of the thesis is to

- Study of Fuzzy inference systems (FIS) and Adaptive neuro fuzzy inference systems
- Performance of ANFIS in propagation environment without path loss
- Performance of ANFIS in propagation environment with path loss

#### **3.2 RESEARCH QUESTIONS:**

Cognitive radio is an intelligent system that helps in efficient utilization of unused spectrum. In spectrum sharing, Quality of Service (Qos) of the primary user has high priority while the secondary user is utilizing the spectrum. In order to maintain the Qos to the primary user, the transmit power of the cognitive user has to be varied so that it does not cause any interference to the primary user.

- How ANFIS can be used for opportunistic power control in cognitive radio?
- How the performance of the secondary user can be increased?
- Which factors influence the power control parameter in different propagation environments?
- How the error is minimized in ANFIS?

#### **3.3 MAIN CONTRIBUTIONS:**

The main contributions of this thesis work to the scientific world are

- Applying ANFIS for Opportunistic power control in Cognitive radio for different propagation environments.
- Implementation of ANFIS using MATLAB.

## 4. FIS AND ANFIS

### 4.1 General Architecture of Rule based Fuzzy model

The general architecture [15] of a rule based fuzzy model consists of five modules as shown in Figure 2. They are

- Input interface
- Rule base
- Data base
- Fuzzy inference
- Output interface

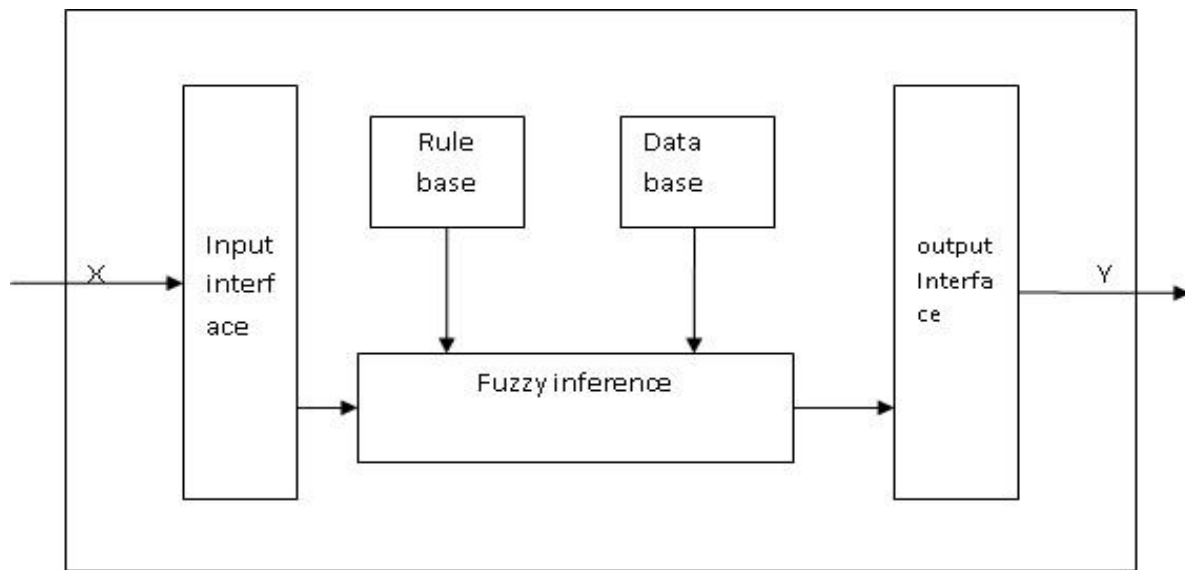

**Figure 2: Rule based Fuzzy model**

The input interface accepts inputs and converts the inputs into a format that the fuzzy inference can use to activate and process the fuzzy rules. In general the input is a fuzzy set

The rule base consist a set of fuzzy if-then rules. It describes the relationship between the input and output.

The data base stores the values of the parameters of the rule based model like detailed definitions of the universes of input and output variables and details of the membership functions.

The fuzzy inference module processes the inputs using the rule base and exploiting the mechanisms of fuzzy inference and approximate reasoning. Fuzzy inference transforms the inputs using fuzzy rules to develop the outputs.

The output interface translates the result of fuzzy inference into a suitable format required by the application environment.

From MATLAB definitions, Fuzzy inference is a process of formulating the mapping from a given input to an output using fuzzy logic. The mapping then provides a basis from which decisions can be made, or patterns discerned. The process of fuzzy inference involves membership functions, logical operations and if-then rules. Fuzzy inference systems have been successfully applied in fields such as automatic control, data classification, decision analysis, expert systems and computer vision.

## 4.2 Important definitions

### Membership function:

Consider a classical set  $X$  with elements  $x_1, x_2, x_3, \dots, x_n$  i.e.,  $= \{x_1, x_2, x_3, \dots, x_n\}$ .

A subset  $A \in X$  can consist of any elements in  $X$ .

We can describe the set  $A$  by a membership function  $\mu_A: X \rightarrow \{0, 1\}$

If we extend the membership function to values in the range of  $[0,1]$  (i.e., all the values between 0 and 1) we can define a fuzzy set  $A$  of  $X$ .

**Antecedent parameters:** The inputs parameters which has been given to fuzzy inference system are called antecedent parameters.

**Consequence parameters:** The output parameters which has been obtained from fuzzy inference system are called consequence parameters.

**Fuzzy rules:** Fuzzy rules are the conditional statements that describes the relationship between the input and output variables. They are of the form "If" and "Then". These rules are obtained by the knowledge available regarding a problem.

Eg: If input is A then output is B

**Fuzzification:** It is a process of converting crisp or classical data into fuzzy data or membership functions.

**Defuzzification:** It is a process of calculating the output using different methods and put them into a lookup table. The output is picked up from the lookup table based on the current input during an application. It converts fuzzy output into crisp output.

### 4.3 TYPES OF FIS SYSTEMS

There are three types of Fuzzy inference systems. They are

- Mamdani fuzzy model
- Takagi –Sugeno fuzzy model
- Tsukamoto Model fuzzy model

#### 4.3.1 Mamdani fuzzy Model:

The mamdani fuzzy inference system was first proposed by E. H. Mamdani as an attempt to control a steam engine and boiler combination from a set of linguistic control rules obtained from experienced human operators. In this model both input and output membership functions are in the form of linguistic variables. To implement this type of fuzzy model one must go through the following steps.

Step 1: Setting the fuzzy rules:

Fuzzy rules are the conditional statements that define the relationship between the input membership functions and output membership functions.

For eg: If input 1 is low and input 2 is high then output is high

Here the values of low, medium and high to the inputs are called linguistic variables or the membership functions. Expert Knowledge is used for this purpose

Step 2: Fuzzification: It is the process of converting crisp data into fuzzy data. The input data is classified into input membership functions which can be linguistic variables like low , medium etc. This is usually done on basis of expert human knowledge.

Step 3: Combining the fuzzified inputs according to the fuzzy rules to establish rule strength. For this purpose fuzzy combinations or T-norms like fuzzy and, fuzzy or and Boolean or are used.

Step 4: Finding the consequence of the rules by combining the rule strength and the output membership function.

Step 5: The outputs of all the fuzzy rules are calculated and combined to get a output distribution.

Step 6: Defuzzification: Usually a crisp output is required in most of the applications. Defuzzification is the process of converting fuzzy data (Output distribution) to crisp data (single value). There are so many methods which can be used for this purpose. Some of the commonly used methods are Center of Mass, Mean of the Maximum etc.

#### **4.3.2 Sugeno fuzzy Model:**

Sugeno fuzzy model also known as TSK fuzzy model was proposed by Takagi, Sugeno and Kang in an effort to develop a systematic approach to generate fuzzy rules from a given input and output data set. In this model the input membership functions can be linguistic variables but the output must be linear or constant. In this model the fuzzy rules are of the form

If x is A and y is B then  $z = f(x,y)$

Where A and B are the fuzzy input membership functions and  $z = f(x,y)$  is the crisp output. Usually the output is a polynomial expression of x and y. The order of the polynomial defines the order of the model. Since the output of each rule is a crisp value, the overall output is calculated as the weighted average of all the rules. Since the output is a crisp value there is no need of defuzzification in this model reducing the complexity when compared to mamdani model. Fuzzification and setting fuzzy rules is to mamdani model and needs human expert knowledge.

If  $z=k$  (constant) then it is known as zero order sugeno model

If  $z=p.x + q . y + r$  which is a first order polynomial of inputs then it is called as first order sugeno model.

#### **4.3.3 Tsukamoto Fuzzy Model:**

This model is proposed by Y. Tsukamoto. The consequent of each fuzzy if-then rule is represented by a fuzzy set with a monotonical membership function. As a result, the inferred output of each rule is defined as a crisp value induced by the rule's firing strength. The overall output is taken as the weighted average of each rule's output. Since each rule infers a crisp output, the Tsukamoto fuzzy model aggregates each rule's output by the method of weighted average and thus avoids the time consuming process of defuzzification . The Tsukamoto fuzzy model is not used often since it is not as transparent as either the Mamdani or sugeno fuzzy model [16] .

#### 4.4 ADAPTIVE NEURO FUZZY INFERENCE SYSTEM (ANFIS)

Adaptive neuro fuzzy inference system(ANFIS) is a type of fuzzy inference system (FIS) which formulates the mapping of inputs to output. It uses both fuzzy logic(FL) and artificial neural networks(ANN) in the process of mapping the inputs to output. In FIS the most difficult part is to obtain membership functions, distribution of membership functions and setting fuzzy rules. These parameters are obtained by using trial and error method. ANFIS uses neural networks to adjust these parameters. The ANN part in ANFIS helps in reducing the error and optimizing the parameters. FL deals with uncertainty very well and known for structured knowledge representation. ANN has the learning capability. ANFIS has the advantages of both FL and ANN. Hence it has become an important step of research in the fields of automatic control, data classification, decision analysis, expert systems and computer vision where FIS has been successfully used. The main objective of ANFIS is to identify the near optimal membership functions and other parameters of the equivalent fuzzy inference system by applying a hybrid learning algorithm using input-output data sets and then to achieve a desired input-output mapping [13].

ANFIS has a layered architecture just like neural networks. ANFIS consists of five layers. The nodes in these layers can be adaptive or fixed. For identification, the adaptive nodes are represented by squares and fixed nodes are represented by circles in the architecture. The general architecture of ANFIS is shown in Figure 3. For description of the architecture, we consider first order sugeno with two inputs  $x$  and  $y$ .

A Takagi-sugeno based ANFIS has rules of the form

If  $X$  is  $A_1$  and  $Y$  is  $B_1$  then  $f_1 = p_1 x + q_1 y + r_1$

If  $X$  is  $A_2$  and  $Y$  is  $B_2$  then  $f_2 = p_2 x + q_2 y + r_2$

Layer 1 : In this layer the nodes are adaptive. The membership values of the inputs are calculated in this layer. The output of the nodes is a membership grade of the inputs.

Output  $O_{1,i}$  for node  $i=1,2$   $O_{1,i} = \mu_{A_i}(x)$

Output  $O_{2,i}$  for node  $i=1,2$   $O_{2,i} = \mu_{B_i}(y)$

$x$  and  $y$  are the inputs to the node  $i$ .  $A_i$  and  $B_i$  are the linguistic labels like small, medium, large etc.  $\mu_{A_i}(x)$  and  $\mu_{B_i}(y)$  can be any membership function like bell shaped, triangular or trapezoidal shaped etc. The number of nodes represents the number of fuzzy sets into which each input is quantified. Usually all the membership functions are in the interval of  $[0,1]$ .  $A_i$  and  $B_i$  are also called as antecedent parameters which are determined and adaptively modified during the training process of ANFIS.

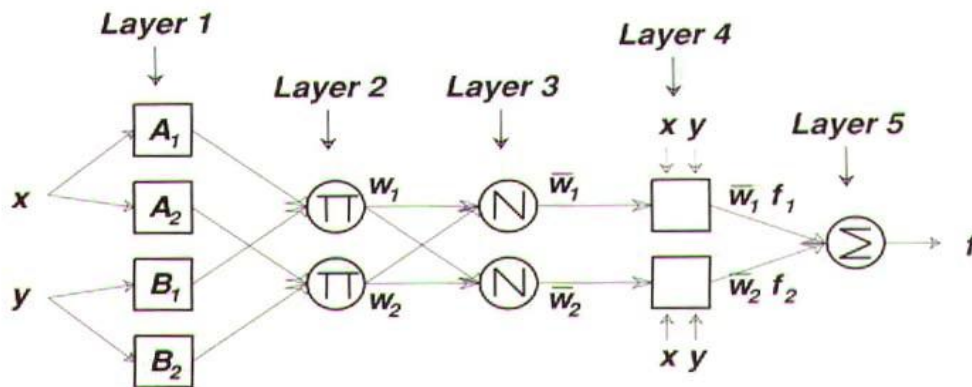

Figure 3 General Architecture of ANFIS

Layer 2: In this layer the nodes are fixed. In this layer the firing strength of each rule is calculated and it represents each node output. T-norm operators are used like min, product, fuzzy AND etc.

$$w_i = \mu_{A_i}(x) \cdot \mu_{B_i}(y) \quad \text{for } i = 1, 2$$

Layer 3: The nodes are fixed in this layer. In this layer all the rules or firing strengths are normalized. The ratio of a particular rule to that of sum of all the rules. The output of the node is usually called as normalized firing strength and is fed to layer 4

$$\text{Output of layer 3 is } \bar{w}_i = \frac{w_i}{\sum w_i} \quad \text{where } i = 1, 2, \dots$$

Layer 4: The nodes are adaptive in this layer. The output or the consequent parameters are determined in this layer. The function of each node is a combination of the output of the layer 3 and a simple linear equation (Sugeno rule). In this layer, the contribution of each rule to the overall output is calculated

$$\text{Output of layer 4 is } \bar{w}_i \cdot f_i = \bar{w}_i (p_i x + q_i y + r_i)$$

In this layer the consequent parameters ( $p_i, q_i, r_i$ ) are determined and adjusted during the training process.

Layer 5: This layer is the output layer. There is only a single node and it is fixed. The function of this layer is the summation of all the inputs or incoming signals (outputs from layer 4).

$$\text{Output of layer 5 (Overall output) is } \sum_i \bar{w}_i \cdot f_i = \frac{\sum_i w_i \cdot f_i}{\sum_i w_i}$$

From layer 1 to layer 4 represents the “if -then” rules of takagi sugeno fuzzy model and also determines the number of fuzzy rules. In layer 1 the input membership functions and antecedent parameters are determined and in layer 4, the consequent parameters are determined. If a zero order sugeno model has to implemented, all the steps will be similar expect the output in layer 4 where  $p=0$  and  $q=0$ .

The training of ANFIS is carried either by back propagation algorithm or Hybrid algorithm. In our thesis we used hybrid algorithm for training purpose. A hybrid algorithm is an algorithm which uses both back propagation algorithm and least mean squares algorithm to determine the input (antecedent) and the output (consequent) parameters. Usually the consequent parameters are updated first by using least mean square algorithm and the antecedent parameters are updated later by back propagating the errors that still exist using gradient descent algorithm. Since two different types of algorithms are used to reduce the error it is called as hybrid algorithm.

There are different types of membership functions that can be used in layer 1. Some of the commonly used membership functions are

Triangular membership function:

The triangular membership function depends on three parameters  $a, b$  and  $c$ . It is expressed as

$$\mu_{triangular}(x) = \begin{cases} 0 & x < a \\ 1 - \frac{|c-x|}{(b-a)/2} & a < x < b \\ 0 & x > b \end{cases}$$

Where  $c$  is center of the of the triangle.  $a$  and  $b$  are the left and right bounds respectively

Trapezoidal membership function:

The trapezoidal membership function depends on four parameters  $a, b, c$  and  $d$ . It is expressed as

$$\mu_{trapezoidal}(x) = \begin{cases} 0 & x < a \text{ or } x > b \\ 1 - \frac{x-a}{c-\frac{d}{2}-a} & a < x < c-\frac{d}{2} \\ 1 & c-\frac{d}{2} < x < c+\frac{d}{2} \\ \frac{b-x}{b-(c+\frac{d}{2})} & c+\frac{d}{2} < x < b \end{cases}$$

Where  $a$  and  $b$  are left and right bounds.  $c$  is the center of the trapezoid and  $d$  is the top width of the trapezoid

In our thesis we have considered trapezoidal membership function for the inputs.

Bell shaped membership function:

The generalized bell shaped membership function depends on three parameters  $a$ ,  $b$  and  $c$ . It is expressed as

$$\mu_{bell}(x) = \frac{1}{1 + \left| \frac{x-c}{a} \right|^{2b}}$$

Where the parameters are used to determine the shape and position of the bell shaped membership function.  $a$  and  $c$  can be used to adjust the width and the center of membership function.  $b$  is usually positive and greater than 0. It is used to control the slopes at the intersecting point.

Gaussian membership function:

The Gaussian membership function depends on two parameters  $\sigma$  and  $c$  and is given by the expression as

$$\mu_{gaussian}(x) = e^{-\frac{[x-c]^2}{2\sigma^2}}$$

Where the parameters  $\sigma$  and  $c$  are used to determine the shape and the position of Gaussian membership function.  $\sigma$  is used to determine the width of the membership function and  $c$  is the center point of the membership function.

The Implementation of ANFIS is shown in the form of flowchart in Figure 4.

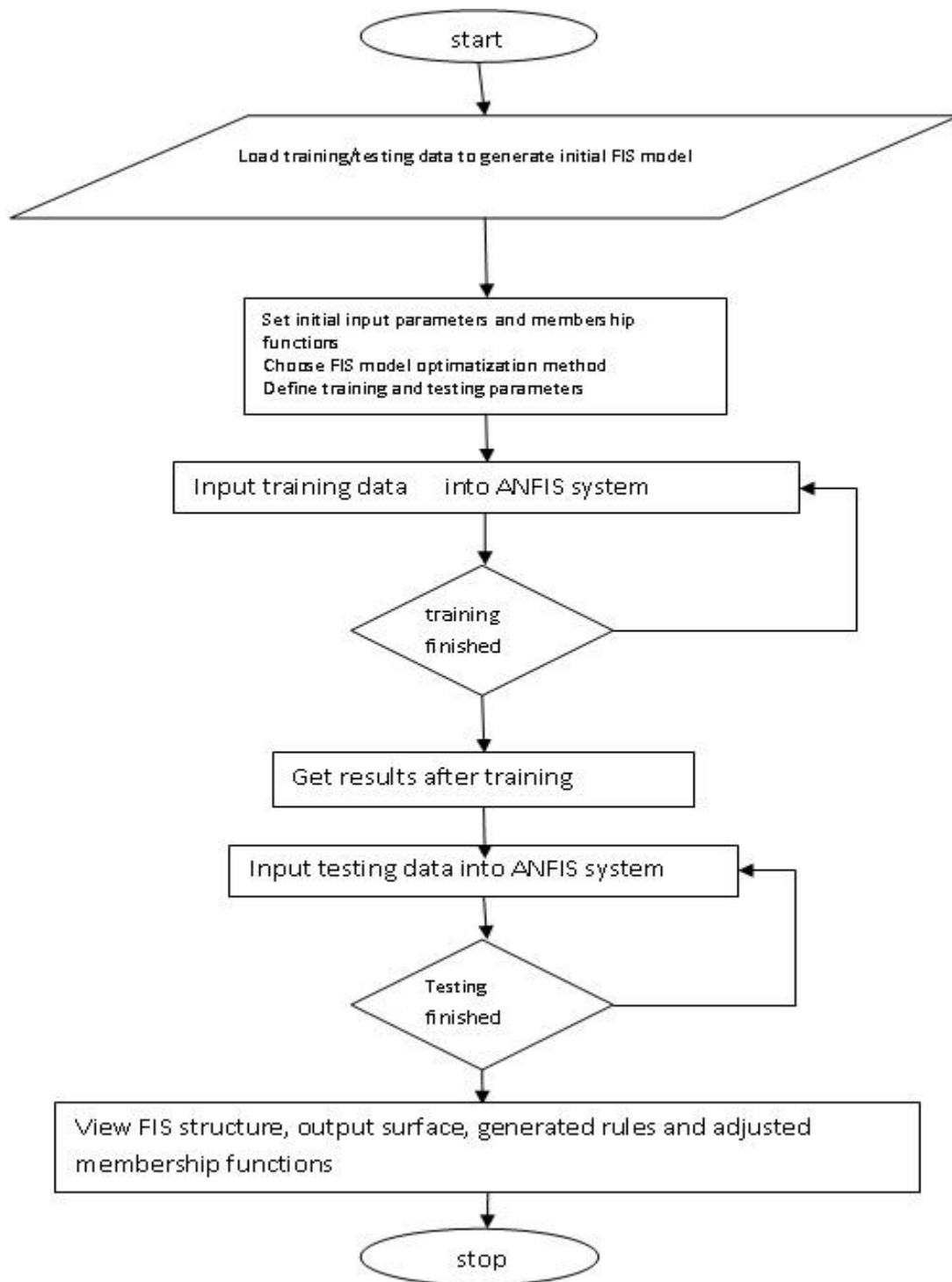

Figure 4: Flow chart of ANFIS implementation

## 5. SYSTEM MODEL

In our thesis we have considered spectrum sharing network in two different scenarios

- Propagation environment without path loss
- Propagation environment with path loss

### 5.1. Propagation environment without path loss

In this propagation environment we have considered a pair of primary users (primary transmitter and primary receiver) and a pair of cognitive users (cognitive transmitter and cognitive receiver) in a Rayleigh fading channel as shown in Figure 5. The channel state information of each transmitting side is known to all those who are available in the network. Both the primary link and the secondary link shares and uses the same spectrum.

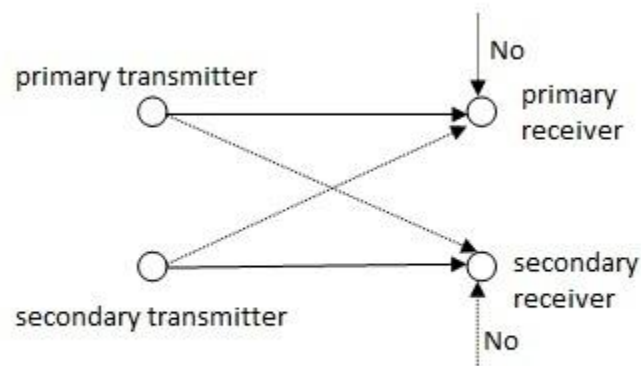

Figure 5 System model of propagation environment without path loss

$G_{pp}$  is the channel gain between the primary transmitter and primary receiver showed by dark link between them.

$G_{cc}$  is the channel gain between the secondary transmitter and secondary receiver showed by the dark link between them.

$G_{cp}$  is the interference channel gain between the primary transmitter and secondary receiver showed by the dotted link between them.

$G_{pc}$  is the interference channel gain between the secondary transmitter and secondary receiver showed by the dotted link between them.

$P_p$  is the power transmitted by the primary transmitter.

$P_c$  is the power transmitted by the secondary transmitter.

All the channel gains are assumed to be random variables acting independently with continuous probability density function.  $N_o$  is the variance of the additive white Gaussian Noise that affects both the primary receiver and the secondary receiver independently in the same way. In this spectrum sharing network, primary link has high priority to transmit data then secondary link. As long as the Qos of the primary user is maintained, the secondary user will be able to use the spectrum. The secondary user's power is regulated so as to maintain the Qos of the primary link

In this scenario we have considered the ratio of signal to noise ratio (SNR) to a threshold value as one input and the ratio of  $G_{cp}$  to its maximum value as the second input to the ANFIS. The output we considered is the ratio of  $P_c$  to its maximum value.

The primary user's Signal to Noise Ratio without the presence of Cognitive user is defined in [8] [9] as

$$SNR = \alpha = \frac{P_p G_{pp}}{N_o}$$

The primary user's Signal to interference noise ratio with the presence of cognitive user in the spectrum sharing network is given in [8][9] as

$$SINR = \beta(k) = \frac{P_p G_{pp}}{k \cdot P_{cmax} G_{cp} + N_o}$$

$P_{cmax}$  is the peak power transmitted by the cognitive user and  $k$  is the instantaneous power control parameter. The value of  $k$  varies in between 0 to 1 whose value will be determined by the power control strategy [9].

In order to maintain the Qos a threshold level  $\beta_t$  is considered which is given in [9] as  $2^{R_p} - 1$ .  $R_p$  is the data rate of the primary link. Primary user's SINR should be greater than the threshold value during spectrum sharing. The Cognitive user varies its power to keep the primary user's SINR greater than the threshold value.

#### **Affect of SNR:**

When the SNR of the primary link falls below the threshold level the primary link is already in outage. In this case the transmission from the cognitive user does not have any negative affect on the primary user, no matter how much transmit power it uses. Hence cognitive user can transmit with its peak power.

In case when the SNR of the primary link is near to the threshold value then the primary user is not in outage and sensitive to interference from the Cognitive user. In this case the cognitive user transmits with fraction of its peak power to maintain QoS to Primary link, so that the primary user can still transmit  $R_p$  with  $P_p$ .

In case when the SNR of the primary link is far above the threshold value, the primary user's SINR will be greater than the threshold value even if the cognitive user transmits with its peak power. As the QoS is assured regardless of cognitive user's transmit power, The Cognitive user transmits with peak power

#### **Affect of interference channel gain ( $G_{cp}$ ) :**

When the primary user's interference channel gain ( $G_{cp}$ ) is low, the Primary user's received interference intensity from the Cognitive link is low. In this case the Cognitive user can transmit with peak power. When the primary user's interference channel gain ( $G_{cp}$ ) is high, the primary user's received interference intensity from the Cognitive link is high and the Cognitive user should transmit with low power.

Using the above theory few rules are formulated in [7][8]. They are

When the primary link is idle, the interference channel gain does not have much effect on the cognitive user's transmit power and cognitive user can transmit with peak power scale.

When the primary link is robust, it means that the primary link is robust to interference and interference channel gain doesn't affect the cognitive user's transmit power and cognitive user can transmit with peak power scale in this case too.

When the primary link is active,  $G_{cp}$  affects the peak power scale of the cognitive user. When  $G_{cp}$  is high the cognitive user should be transmitting with low power scale and if  $G_{cp}$  is low, the cognitive user should be transmitting with high power scale.

In order to illustrate the ANFIS based power control strategy we have also considered similar inputs as that in [7][8]. We have considered the ratio of SNR to the threshold value as one input and the primary user's interference channel gain to its maximum value as the second input. The output that we have peak power scale ratio  $k$  of cognitive user which is similar to that in [7][8]. It is also called as instantaneous power control parameter in [9]. For ANFIS we need training data sets which is the combination of inputs and output. We have used the above discussed theory and rules for training purpose.

## 5.2. Propagation environment with path loss:

The second scenario that we considered is a spectrum sharing network in the propagation environment with path loss as shown in Figure 6. In this scenario distance between the transmitter and the receiver and distance between the links also affects the interference [10][11]. So we have considered distance as one of the parameter that influences the peak power scale.

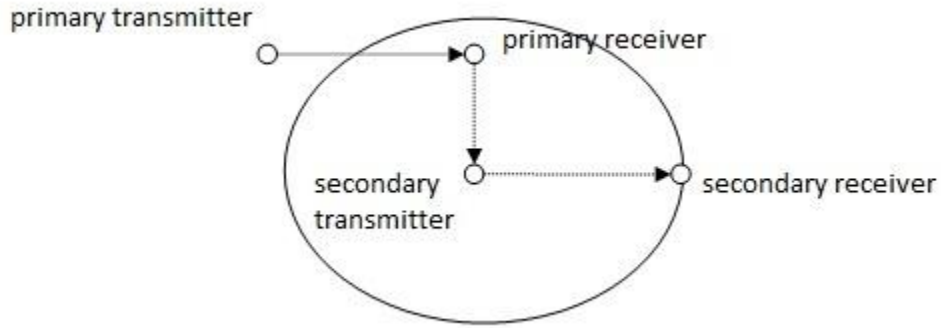

Figure 6 System model of propagation environment with path loss

$d_{pp}$  is the distance between the primary transmitter and primary receiver.

$d_{cc}$  is the distance between the secondary transmitter and secondary receiver.

$d_{cp}$  is the distance between the secondary transmitter and primary receiver.

Beyond a certain distance the influence of the received power intensity is considered as zero and this distance is called a maximum effective distance. The relationship between the received power and transmitted power in terms of distance is given in [8] as

$$P_{rt} = P_{pt} \cdot A \left[ 1 - \left( \frac{d_{pp}}{L_{pp}} \right)^n \right]$$

Where  $P_{rt}$  is the power received at the receiver and  $P_{pt}$  is the power transmitted by the transmitter.  $A$  is the frequency dependent path loss constant [10].  $L_{pp}$  is the maximum effective distance,  $n$  is the path loss exponent which should be greater than or equal to 2.  $d_{pp}$  is less than or equal to  $L_{pp}$  [8].

Using the equation 3 in 1 gives

$$SNR = \alpha = \frac{P_{pt} A \left[ 1 - \left( \frac{d_{pp}}{L_{pp}} \right)^n \right] \cdot G_{pp}}{N_o}$$

Using the equation 3 in 2 gives

$$SINR = \beta(k) = \frac{P_{pt} A \left[ 1 - \left( \frac{d_{pp}}{L_{pp}} \right)^n \right] \cdot G_{pp}}{k \cdot P_{ctmax} A \left[ 1 - \left( \frac{d_{cp}}{L_{cp}} \right)^n \right] G_{cp} + N_o}$$

Where  $P_{ct}$  is the power transmitted by the cognitive transmitter.

Now the value of k is influenced by SNR, primary user's interference channel gain and also the relative distance. For explaining the relationship between the SNR and relative distance, the primary user's interference channel gain is fixed as one in order to exclude its influence. Thus the power control parameter is influenced by SNR and relative distance.

In order to maintain the Qos a threshold level  $\beta_t$  is considered similarly as it was in first environment and the affect of the SNR is also the same as explained in first scenario.

### **Affect of Relative distance**

When the relative distance is small, the interference caused by the cognitive link will be high and so the Cognitive user should transmit will low power scale. When the relative distance is large then the interference caused by the cognitive link will be low, so the cognitive user can transmit with peak power scale.

Using the above theory few rules are formulated in [7][8]. They are

When the primary link is idle, the relative distance does not have much effect on the cognitive user's transmit power and cognitive user can transmit with peak power scale.

When the primary link is robust, it means that the primary link is robust to interference and again the relative distance doesn't affect the cognitive user's transmit power and cognitive user can transmit with peak power scale in this case too.

When the primary link is active, relative distance affects the peak power scale of the cognitive user. When relative distance is low the cognitive user should be transmitting with low power scale and if relative distance is high, the cognitive user should be transmitting with high power scale.

In order to illustrate the ANFIS based power control strategy in the propagation environment with path loss, we have also considered similar inputs as that in [7][8]. We have considered the ratio of SNR to the threshold value as one input and relative distance to its maximum effective distance as the second input. The output that we have peak power scale ratio  $k$  of cognitive user which is similar to that in [7][8]. For ANFIS we need training data sets which is the combination of inputs and output. We have used the above discussed theory and rules for training purpose.

## 6. IMPLEMENTATION AND RESULTS

### Structure of ANFIS

The Figure 1 shows the generated ANFIS structure using MALAB. The two inputs that we considered are the ratio of SNR to the threshold value and the ratio of primary user interference channel gain ( $G_{cp}$ ) to its maximum value which are represented by the black dots. The output is also represented by black dot which is the power scale ratio (k). After the training is done the above structure is obtained. The layer 1 in ANFIS is represented by “inputmf” in the Figure 7.

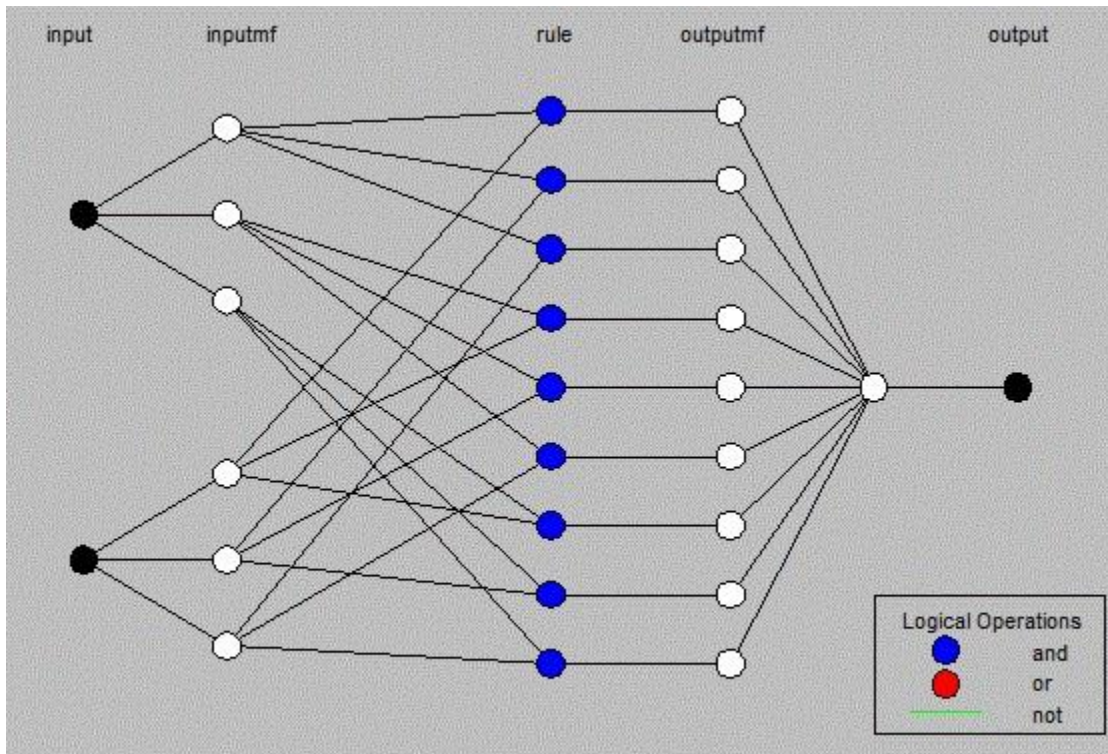

Figure 7: Structure of ANFIS

## Membership functions

The first input to ANFIS is the ratio of SNR to the threshold value. After training the obtained membership function for this input is shown in the Figure 8. In the Figure “in1mf1” is concerned to “idle”. “in1mf2” is concerned to “active”. “in1mf3” is concerned to “robust”.

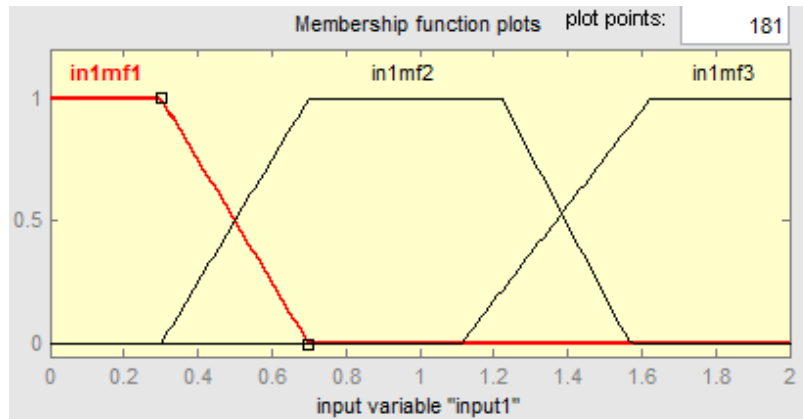

Figure 8: Membership function of  $\frac{\alpha}{\beta_t}$

The second input is the ratio of primary user’s interference channel gain to its maximum value. The membership function shown in Figure 9 is obtained after training. “in2mf1” is concerned to “low”. “in2mf2” is concerned to “medium”. “in2mf3” is concerned to “high”.

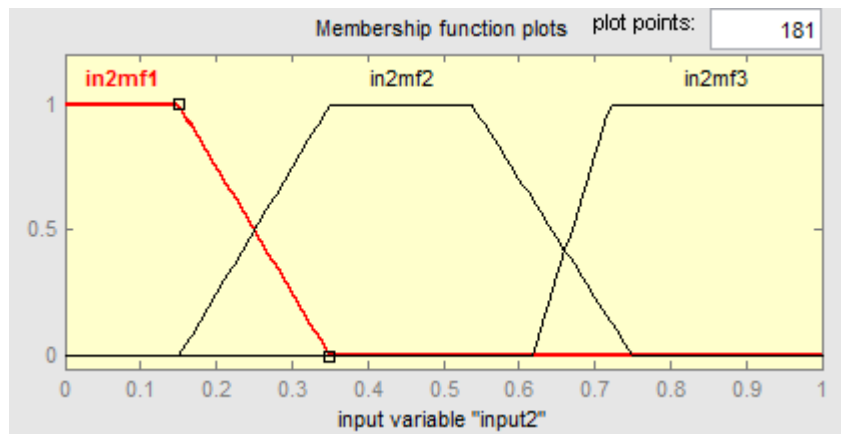

Figure 9: Membership function of  $\frac{G_{cp}}{G_{cp\ max}}$

### Error Minimization and Surface plot:

During the training process, the input and output parameters are adjusted and the error is minimized for each and every epoch. Hybrid algorithm is used for minimizing the error. The error minimization is shown in the Figure 10. After 80 epochs the error is minimized to 0.082.

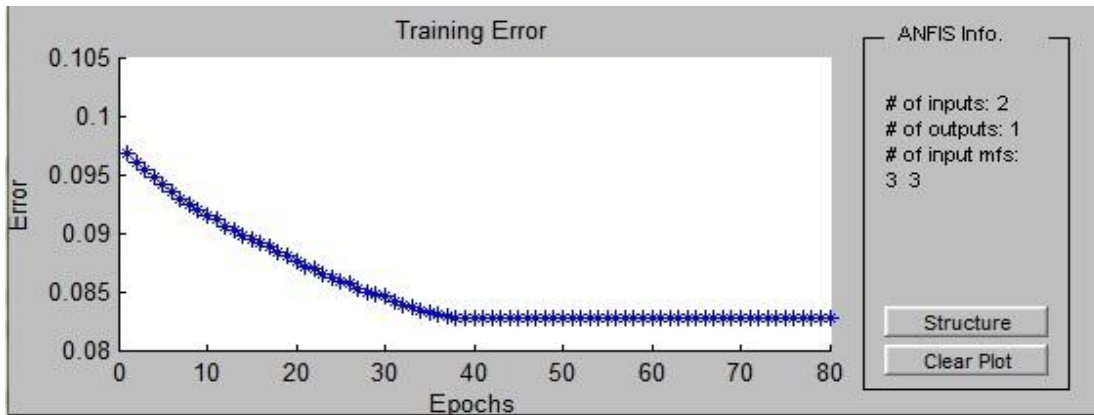

Figure 10: Error minimization graph

The surface graph of the two inputs is shown in the Figure 11. From the surface graph we can tell how the inputs affect the output. When both the inputs are low  $\left(\frac{\alpha}{\beta_t}, \frac{G_{cp}}{G_{cp\ max}}\right)$  the output is high. When both the inputs are high, the output is again high. When input 1  $\left(\frac{\alpha}{\beta_t}\right)$  is medium and and input 2  $\left(\frac{G_{cp}}{G_{cp\ max}}\right)$  is high the output is low.

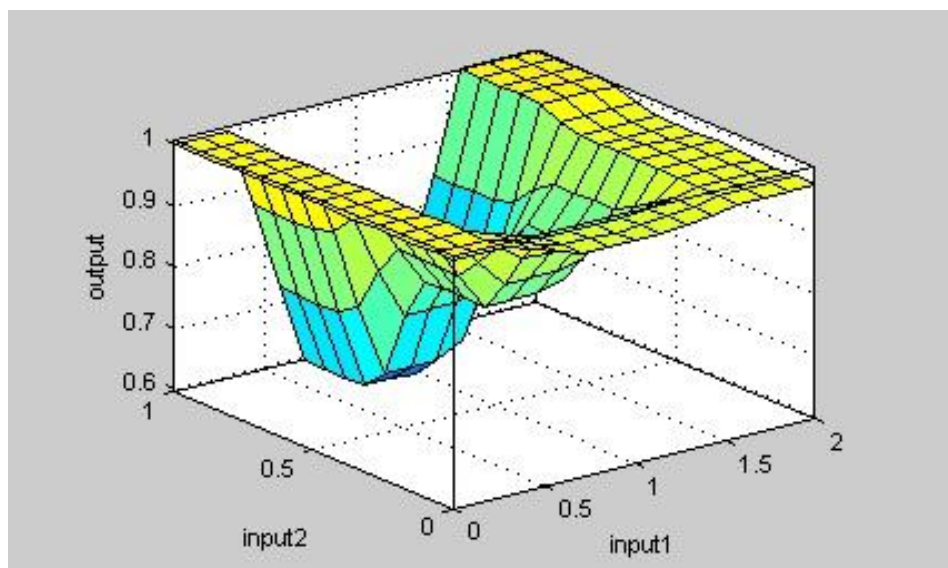

Figure 11: Surface graph

### Performance of proposed strategy

The performance of a system can be observed by plotting the Bit Error rate versus the ratio of energy for bit to Noise power using BPSK modulation scheme. We did the comparison between system without power control and system with ANFIS based power control in the propagation environment without path loss in a fading channel. From the graph we can say that the secondary user's performance is improved while maintaining the Qos of the primary link.

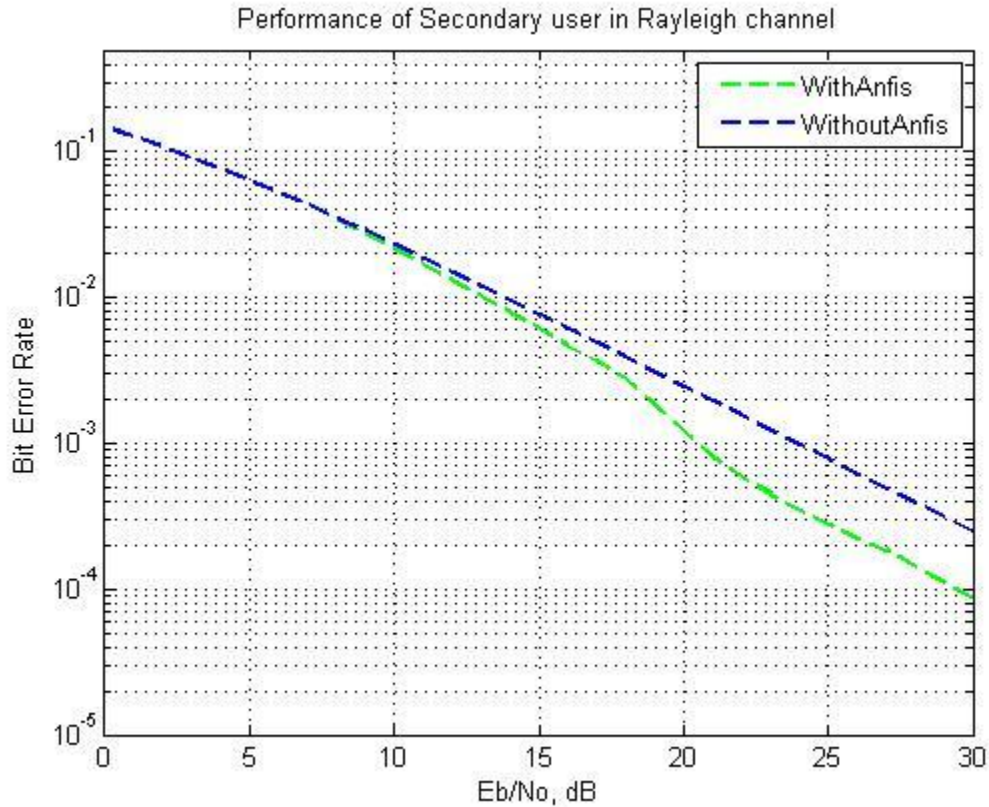

Figure 12: Performance of secondary user

### Membership functions for propagation environment with path loss

In the propagation environment with path loss the inputs that we considered are the ratio of SNR to the threshold value  $\left(\frac{\alpha}{\beta_t}\right)$  and the ratio of relative distance to maximum effective distance  $\left(\frac{d_{cp}}{L_{cp}}\right)$ .

The first input to ANFIS is the ratio of SNR to the threshold value. After training the obtained membership function for this input is shown in the Figure 13. In the Figure “in1mf1” is concerned to “idle”. “in1mf2” is concerned to “active”. “in1mf3” is concerned to “robust”.

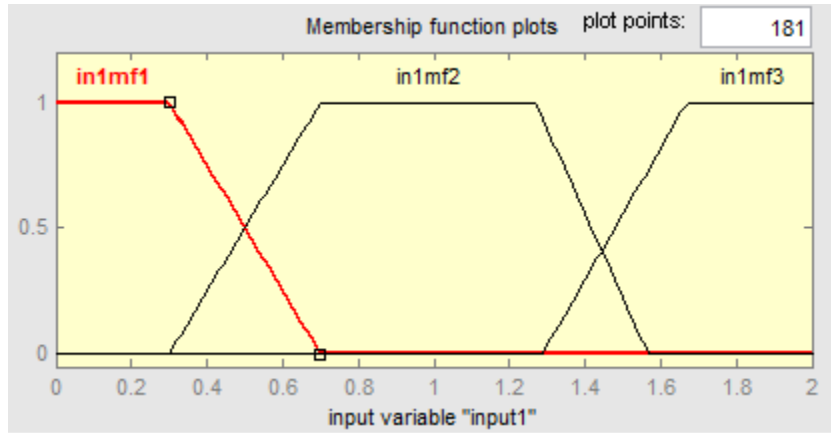

Figure 13: Membership function of  $\frac{\alpha}{\beta_t}$  in second scenario

The second input is the ratio of relative distance to the maximum effective distance  $\left(\frac{d_{cp}}{L_{cp}}\right)$ . The membership function shown in Figure 14 is obtained after training. “in2mf1” is concerned to “low”. “in2mf2” is concerned to “medium”. “in2mf3” is concerned to “high”.

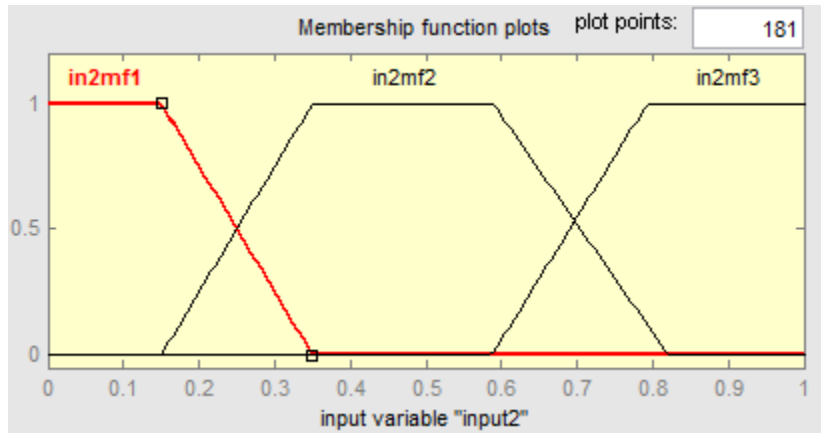

Figure 14: Membership function of  $\frac{d_{cp}}{L_{cp}}$  in second scenario

### Error Minimization and Surface plot:

The error minimization plot for the propagation environment with path loss is shown in the Figure 15. After 80 epochs the error is minimized to 0.049.

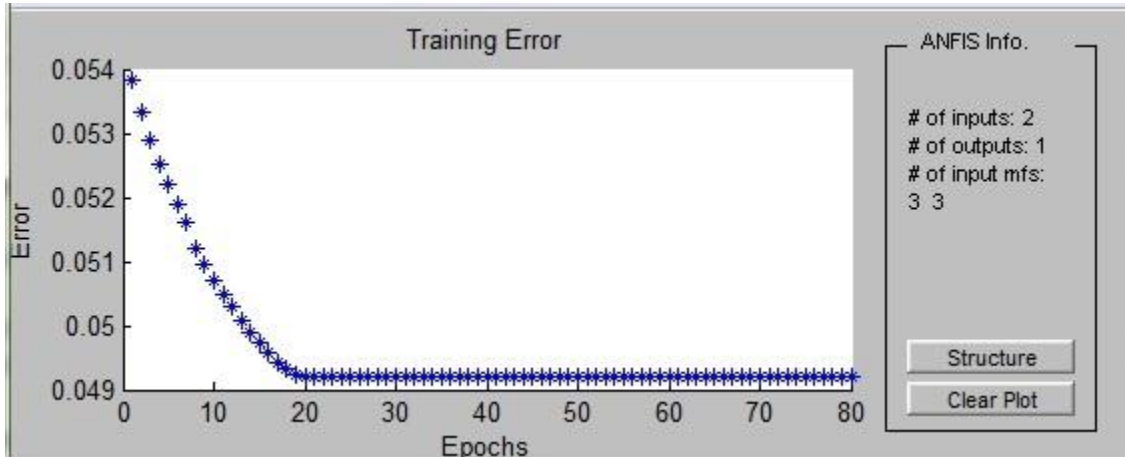

Figure 15: Error minimization plot for scenario 2

The surface graph for propagation environment with path loss of the two inputs is shown in the Figure 16. From the surface graph we can tell how the inputs affect the output. When both the inputs are low  $\left(\frac{\alpha}{\beta_t}, \frac{d_{cp}}{L_{cp}}\right)$  the output is high. When both the inputs are high, the output is again high. When input 1  $\left(\frac{\alpha}{\beta_t}\right)$  is medium and and input 2  $\left(\frac{d_{cp}}{L_{cp}}\right)$  is low the output is low.

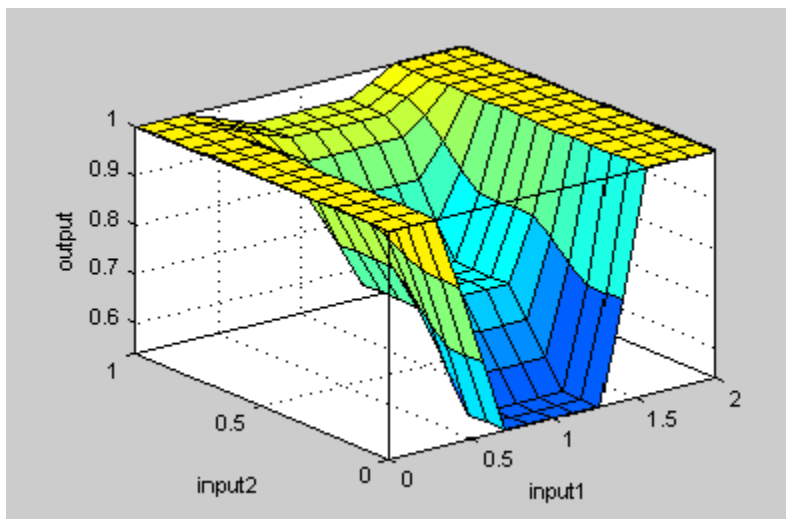

Figure 16: Surface graph for propagation environment with path loss

## 7. CONCLUSION AND FUTURE WORK

For the next generation communication, there is a huge demand for mobile & broadband applications. One demand is that pictures and video are very efficient in describing a situation. Another demand is that modern cell phones have broadband internet access, and public safety personnel may start to rely on it. But during a large emergency, cell phones are likely to fail. Therefore, broadband internet access is a requirement for the next generation public safety communication system. The main problem is that spectrum in the public safety bands is scarce, and public safety communication has such a high peak-to-average ratio that it is uneconomical to reserve the needed spectrum in the conventional way. Cognitive radio could be a way out of this problem. However, cognitive radio is not allowed to interfere with the primary voice communication in any way. So in our thesis we proposed how power management could be done without interfering primary user and maintain a QoS.

In a spectrum sharing network, improving the performance of the secondary user and minimizing the interference to the primary link are two conflicting goals. In our thesis we proposed ANFIS based power control strategy to improve the performance of the secondary user by maintaining the QoS to the primary link. Simulation results show that bit error rate of the proposed strategy is less than the one without power control.

Thus we conclude that ANFIS can be efficiently used for power control in cognitive radio which helps in improving the performance of the secondary user. Using FIS, QoS of the primary user is adhered and there is no need of complex feedback channel.

For Future work, the proposed strategy can be extended to the network with multiple primary users and multiple cognitive users so that each cognitive user has a choice to select the best primary link that it can coexist with, in order to improve the efficient utilization of spectrum.

## 8. REFERECE LIST (odd page)

- [1] J. Mitola III and G. Q. Maguire, "Cognitive radio: making software radios more personal," *IEEE J. personal communications*, vol. 6, pp. 13-18, Aug. 1999.
- [2] J. Mitola III, "Cognitive radio- An integrated agent architecture for software defined radio" Ph.D. dissertation, KTH, Stockholm, 2000.
- [3] S. Srinivasa and S. A. Jafer, "Soft sensing and optimal power control for cognitive radio" *IEEE J. transactions on wireless commun.*, vol. 9, pp. 3638-3649, 2010.
- [4] J. S. R. Jang, "ANFIS : Adaptive-Network-Based Fuzzy Inference System" *IEEE Trans. Systems, Man and Cybernetics*, vol. 23, no. 3, pp. 665-685, May/June, 1993.
- [5] S. Haykin, "Cognitive radio: brain empowered wireless communications," *IEEE J. Selected areas in Commun.*, vol. 23, pp. 201-220, Feb. 2005.
- [6] X. P. Gao, W. J. Lei and X. Z. Xie, "Optimal power control for secondary system based on spectrum sharing," in *Communications and Information Technologies International symposium*, Hangzhou, 2011, pp. 84-88.
- [7] A. Dey, S. Biswas and S. Panda, "A new fuzzy rule based power management scheme for spectrum sharing in cognitive radio," in *Communication and Industrial Application International Conf.*, kolkatta, West Bengal, 2011, pp. 1-4.
- [8] J. S. Yu, "Optimal power control in Cognitive radio network with Fuzzy logic" Master's thesis, Dept. Elect. Eng., BTH Univ., Sweden, 2010.
- [9] Y. Chen, G. Yu, Z. Zhang, H. Chen and P. Qiu, "On Cognitive radio networks with opportunistic power control strategies in fading channel," *IEEE Trans. on Wireless Commun.*, vol. 7, no. 7, pp. 2752-2761, Jul. 2008.
- [10] M. Vu, N. Devroye and V. Tarokh, " On the Primary exclusive region of Cognitive Networks," *IEEE Trans. on Wireless Commun.*, vol. 8, no. 7, pp. 3380-3385, Jul. 2009.
- [11] H. Cho and J. G. Andrews, "Upper bound on the Capacity of Cognitive radio without Cooperation," *IEEE Trans. on Wireless Commun.*, vol. 8, no. 9, pp. 4380-4385, Sept. 2009.
- [12] P. Tahmasebi, A. Hezarkhani. (2010). Application of Adaptive Neuro-Fuzzy Inference system for Grade Estimation; Case Study, Sarcheshmeh Porphyry Copper Deposit, Kerman, Iran. *Aust. J. Basic & Appl. Sci.*, [online]. 4(3), pp. 408-420. Available: [http://stanford.academia.edu/PejmanTahmasebi/Papers/178689/Application\\_of\\_Adaptive\\_Neuro-Fuzzy\\_Inference\\_System\\_for\\_Grade\\_Estimation\\_Case\\_Study\\_Sarcheshmeh\\_Porphyry\\_Copper\\_Deposit\\_Kerman\\_Iran](http://stanford.academia.edu/PejmanTahmasebi/Papers/178689/Application_of_Adaptive_Neuro-Fuzzy_Inference_System_for_Grade_Estimation_Case_Study_Sarcheshmeh_Porphyry_Copper_Deposit_Kerman_Iran)
- [13] Z. S. Lee, "ANFIS based Power control for Fixed Broadband Wireless access systems," Ph.D. dissertation, Dept. Comm. Eng., National Central Univ., Taiwan, 2008.

- [14] S. Hiremath and S. K. Patra, "Transmission rate prediction for Cognitive Radio using Adaptive Neural Fuzzy Inference System," in *International conf. on Industrial and Information Systems*, 2010, pp. 92-97.
- [15] W. Pedrycz and F. Gomide, "Rule based fuzzy models," in *Fuzzy systems engineering*, Ed. New Jersey: Wiley, 2007, pp. 276-333.
- [16] J. S. R. Jang, C. T. Sun and E. Mizutani, "Fuzzy inference systems" in *Neuro fuzzy and soft computing*, New Jersey: Prentice Hall, 1997, ch. 4, pp. 73-92.